

Introduction:

C8209HP is an advanced USB module for muC112P camera from COMedia Ltd. It is hardware compatible with muC103P as well as muC110P. The module automatically detects the connected camera upon power-up, allowing customers to build a versatile video system that supports multiple cameras. An integrated LED control circuit provides optimal lighting for camera illumination.

Key Features

- ✓ Resolution: 720*720@30fps
- ✓ Interface: USB 2.0, type C connector
- ✓ Protocol: UVC, no driver is needed for PC/NB
- ✓ Power: 5V by USB port
- ✓ Built in LED driving circuit for external LED
- ✓ Good for some kernel of Linux OS
- ✓ One status LED to indicate operation status
- ✓ AWB Function
- ✓ Two user defined keys
- ✓ C8209HP supplies max constant current at 300mA for external

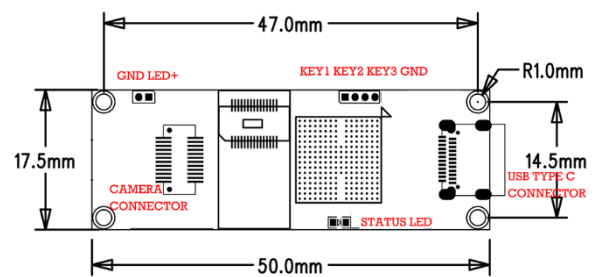

Top View

Block Diagram

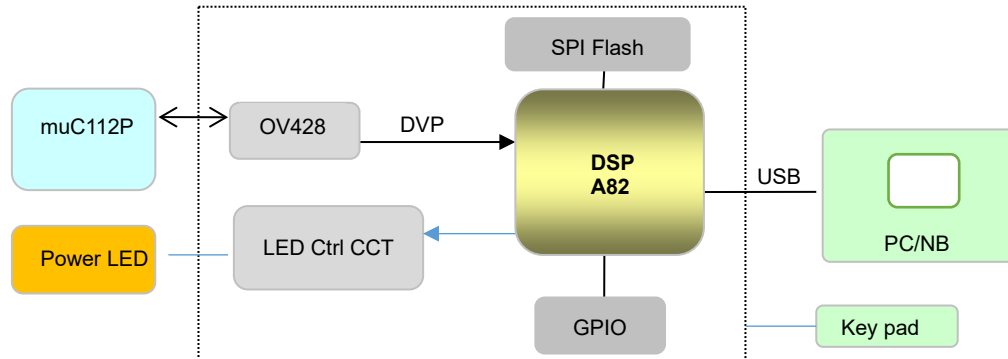

GPIO and Keys Design

1. D1: Status LED to indicate the working status:
 - a. ON - power on & standby
 - b. Blinking – video streaming
2. J1: Key 1 - Calibrate white balance.
Key 2 – user defined key
Key 3 - user defined key
3. J5: external LED connector

Electrical Characteristics

	Condition	Typ.	Unit
Operation voltage	Supply by PC USB port	5	V
Operation current	Video streaming without LED on	105	mA
Standby current	No streaming but plugged in PC	100	mA

Operation

1. Preparation
 - a. Plug in camera module muC112P, note the orientation of connector. Wrong polarity may cause damage of camera.
 - b. Plug in the external LED connector, note the LED power should meet the requirement as abovementioned.
 - c. Plug in the key board, if available.
 - d. Connect to PC/NB thru USB cable with one end type C connector plug to the module
2. Preview in PC
 - a. Before you can preview video on PC screen, you need to have PC cam viewer, such as Amcap from Microsoft.
 - b. It is UVC compliance, no need to install driver manually but you need to wait a while when first time plug in the camera. It will install the right driver by itself. You will find there is USB camera listed in PC hardware manager after that.
 - c. When turn on the software, video will stream on the screen, external LED will be on. If software stopped, LED will be off as well.
3. White balance calibration
 - a. To do white balance calibration, point the camera to a white target, press and hold Key1, it will calibrate the color and make RGB channel balance. Release key in 2-3 seconds.
 - b. If it is under or over exposure, it may not do the calibration correctly.
4. Snap shot or video recording

Customer can develop his own software for video preview and with snap shot or video recording function. Please refer to the appendix for detail implementation of the functions. When these functions have been implemented, follow the below operation to take snap shot or record a video clip.

 - a. Press once Key2, PC software will get a trigger signal and store the current frame to the buffer and save if needed
 - b. Press once Key3, PC software will get a trigger signal and start recording until there is another trigger from module, then stop, save a file on PC

Appendix – Implementation of snapshot and video recording function

UVC protocol has Video Capture Filter, inside the filter, there is a "gain" parameter. Default value is 0. When Key2 is pressed. The "gain" value is set to 1. When Key3 is pressed. The "gain" value is set to 2. The PC software should continuously detect the gain value in the background, do related operations and then set "gain" value to 0.

For example:

PC Software detects gain value = 1, take a picture and set gain to 0 and wait for next value changes.